

Special Relativity: Science Understanding Outcomes

- observations of objects travelling at very high speeds cannot be explained by Newtonian physics. These include the dilated half-life of high-speed muons created in the upper atmosphere, and the momentum of high-speed particles in particle accelerators
- Einstein's special theory of relativity predicts significantly different results to those of Newtonian physics for velocities approaching the speed of light
- the special theory of relativity is based on two postulates: that the speed of light in a vacuum is an absolute constant, and that all inertial reference frames are equivalent
- motion can only be measured relative to an observer; length and time are relative quantities that depend on the observer's frame of reference

This includes applying the relationships

$$l = l_0 \sqrt{\left(1 - \frac{v^2}{c^2}\right)} \quad t = \frac{t_0}{\sqrt{\left(1 - \frac{v^2}{c^2}\right)}} \quad u = \frac{v + u'}{1 + \frac{v u'}{c^2}} \quad u' = \frac{u - v}{1 - \frac{u v}{c^2}}$$

- relativistic momentum increases at high relative speed and prevents an object from reaching the speed of light

This includes applying the relationship

$$p_v = \frac{m v}{\sqrt{\left(1 - \frac{v^2}{c^2}\right)}}$$

- the concept of mass-energy equivalence emerged from the special theory of relativity and explains the source of the energy produced in nuclear reactions

This includes applying the relationship

$$E = \frac{m c^2}{\sqrt{1 - \frac{v^2}{c^2}}}$$

NOT IN SYLLABUS

WACE 2019

DATA SHEET

YOU TRY

Beyond the syllabus.... But could make an appearance in future exams

Relevant Questions from past WACE Exams

Relevant information from the Formulae and Data Booklet

Pause the video and try the question.

Speed of Light is *invariant*.

In 1875s, Albert Michelson measured the speed of light to 99.6 % accuracy by bouncing light off spinning mirrors from distances of 2000 feet away. This became the accepted measurement for the next 40 years and Albert received some high notoriety in the scientific community for this feat.

Having established that light is a wave, though, we still haven't answered one of the major objections raised above. All of the, 'then' knowledge of wave motion is that waves require a medium to permeate through. Sound travels faster through a medium that is harder to compress: the material just springs back faster, and the wave moves through more rapidly. For media of equal springiness, the sound goes faster through the less heavy medium, essentially because the same amount of springiness can push things along faster in a lighter material. So, when a sound wave passes, the material—air, water or solid—waves as it goes through. Taking this as a hint, it was 'then' natural to suppose that light must be just waves in some mysterious material, which was called the **aether**, surrounding and permeating everything.

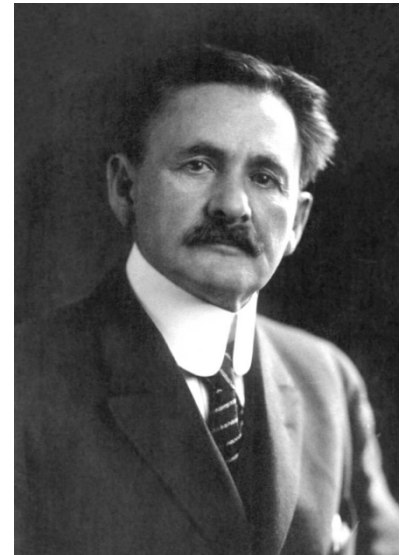

Albert Michelson 1852 -1931

This aether must also fill all of space, out to the stars, because we can see them, so the medium must be there to carry the light. (We could never *hear* an explosion on the moon, however loud, because there is no air to carry the sound to us.) Let us think a bit about what properties this aether must have. Since light travels so fast, it must be very light, and very hard to compress. Yet, as mentioned above, it must allow solid bodies to pass through it freely, without aether resistance, or the planets would be slowing down. Thus, we can picture it as a kind of ghostly wind blowing through the earth. But how can we prove any of this? Can we detect it?

Detecting the aether wind was the next challenge Michelson set himself after his triumph in measuring the speed of light so accurately. Naturally, something that allows solid bodies to pass through it freely is a little hard to get a grip on. But Michelson realized that, just as the speed of sound is relative to the air, so the speed of light must be relative to the aether. This must mean, if you could measure the speed of light accurately enough, you could measure the speed of light travelling upwind, and compare it with the speed of light travelling downwind, and the difference of the two measurements should be twice the windspeed. Unfortunately, it wasn't that easy. All the recent accurate measurements had used light travelling to a distant mirror and coming back, so if there was an aether wind along the direction between the mirrors, it would have opposite effects on the two parts of the measurement, leaving a very small overall effect. There was no technically feasible way to do a one-way determination of the speed of light. At this point, Michelson had a very clever idea for detecting the aether wind. As he explained, it was based on the following puzzle:

Suppose we have a river of width w (say, 100 feet), and two swimmers who both swim at the same speed v feet per second (say, 5 feet per second). The river is flowing at a steady rate, say 3 feet per second. The swimmers race in the following way: they both start at the same point on one bank. One swims directly across the river to the closest point on the opposite bank, then turns around and swims back. The other stays on one side of the river, swimming upstream a distance (measured along the bank) exactly equal to the width of the river, then swims back to the start. Who wins?

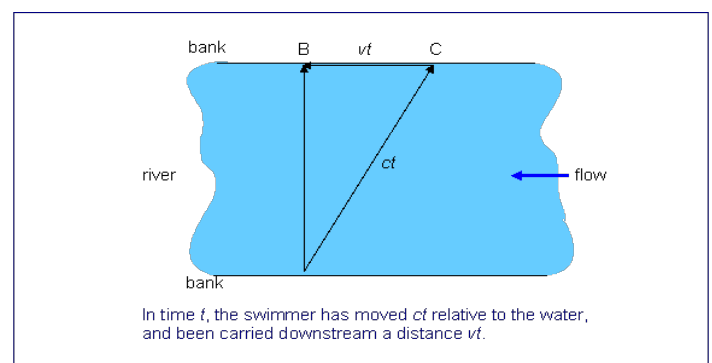

Michelson-Morley Experiment

Michelson's great idea was to construct an exactly similar race for pulses of light, with the aether wind playing the part of the river. The scheme of the experiment is as follows: a pulse of light is directed at an angle of 45 degrees at a half-silvered, half transparent mirror, so that half the pulse goes on through the glass, half is reflected. These two half-pulses are the two swimmers. They both go on to distant mirrors which reflect them back to the half-silvered mirror. At this point, they are again half reflected and half transmitted, but a telescope is placed behind the half-silvered mirror as shown in the figure so that half of each half-pulse will arrive in this telescope.

Now, if there is an aether wind blowing, someone looking through the telescope should see the halves of the two half-pulses to arrive at slightly different times, since one would have gone more upstream and back, one more across stream in general. To maximize the effect, the whole apparatus, including the distant mirrors, was placed on a large turntable so it could be swung around.

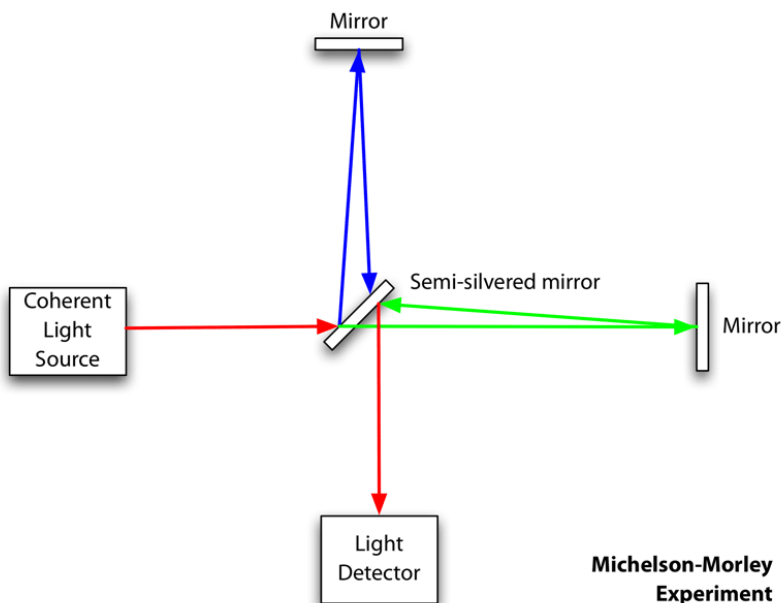
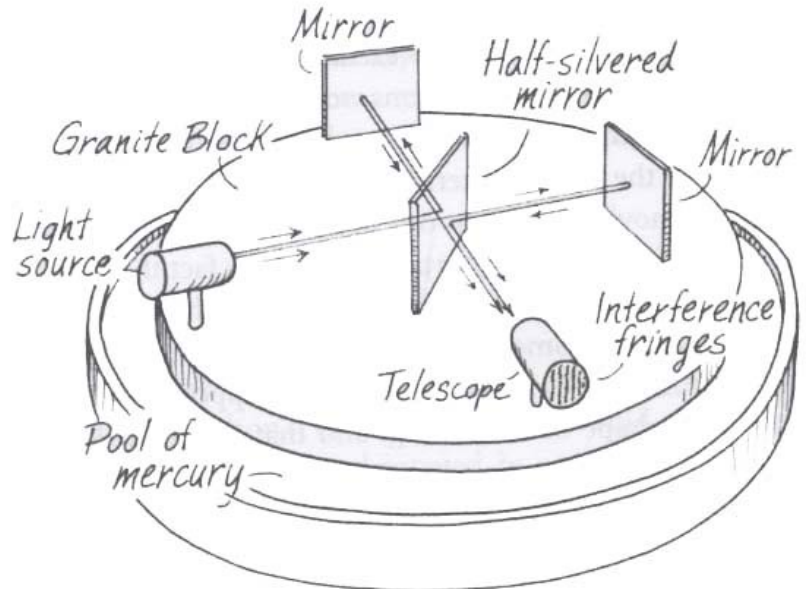

BUT.....Famously, the experiment showed NO interference which suggests that the speed of light is a CONSTANT for all observers.

NULL EXPERIMENT!

Speed of light = $c = 3.00 \times 10^8 \text{ ms}^{-1}$
for all observers.

Einstein's Theory of Special Relativity

Einstein saw this famous NULL result and it helped him develop his theory of special relativity.

The First Postulate states that:

“The laws of physics are the same in any inertial (non-accelerating) frame of reference.”

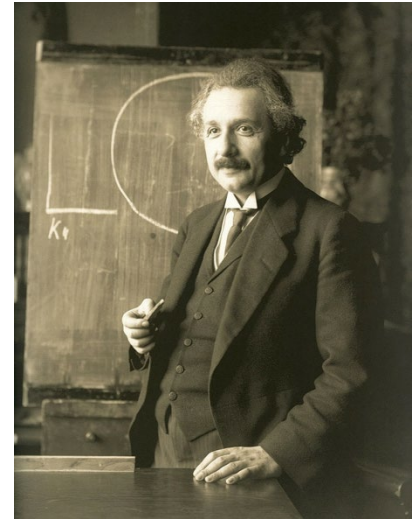

Albert Einstein c.1921

This means that the laws of physics observed by a hypothetical observer travelling close to c must be the same as those observed by an observer who is stationary. If we conducted an experiment in a fast-moving frame of reference, you would get the same results if it were carried out in a slow, or stationary frame of reference. This does not mean that things behave in the same way on the earth and in space, for example an observer on earth is affected by the earth's gravity, but it does mean that the **effect** of a force on an object is the same regardless of what causes the force and also of where the object is or what its speed is.

The Second postulate states that:

“The speed of light will be seen to be the same relative to any observer and therefore independent of the motion of the observer.”

This is the crucial idea that led Einstein to formulate his theory. It means we can define a quantity c , the speed of light, which is a fundamental constant of nature. It means velocities (and speeds) do not simply 'add'. For example, if a rocket is moving at the speed of light relative to an observer, and the rocket fires a missile at $1/10$ of the speed of light relative to the rocket, the missile does not exceed the speed of light relative to the observer.

These two statements must be ROTE learnt. Full definition required to be awarded marks

Simultaneity

A consequence of the finite nature of light.

"Two events that are simultaneous in one frame of reference are not necessarily simultaneous in another"

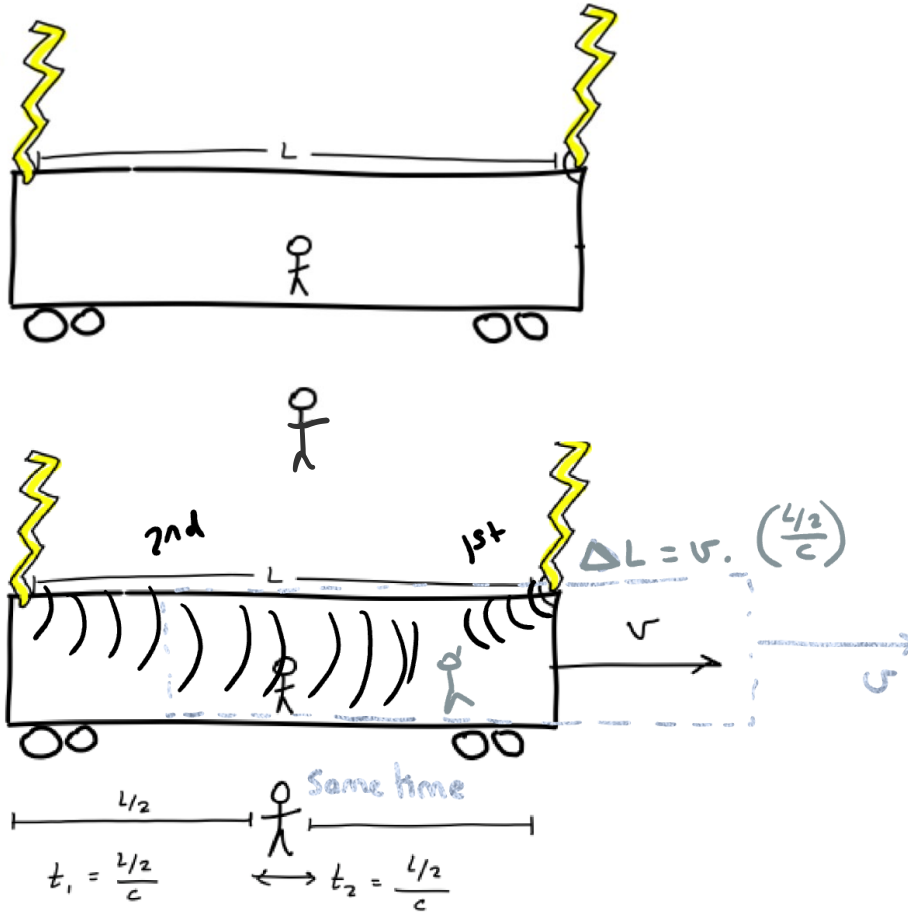

Einstein's "Gedanken"

Einstein suggested a thought experiment where two observers were placed in different frames of reference.



T_0 = proper time
or stationary time
(in some reference
frame)

T = measured time
in different
reference frame.

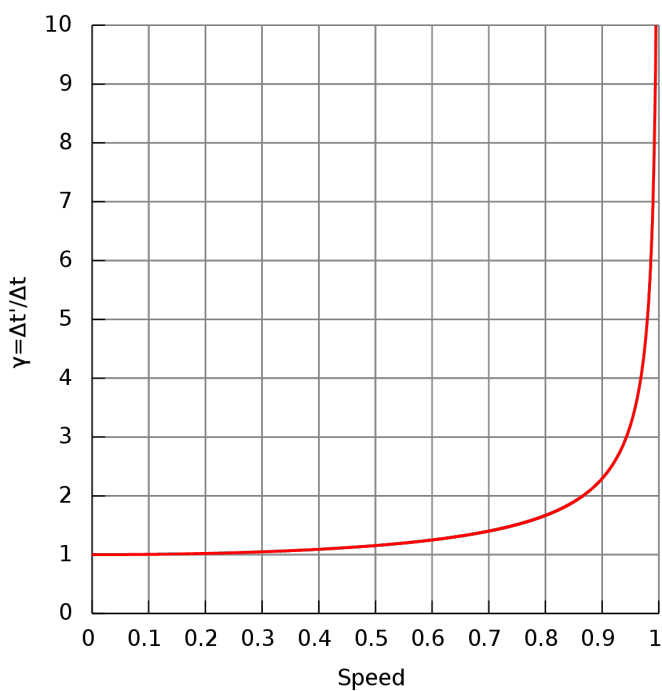

DATA SHEET

$$t = \frac{t_0}{\sqrt{1 - \frac{v^2}{c^2}}}$$

Time Dilation

“Moving clocks tick slower” – for a stationary observer.

The Muon

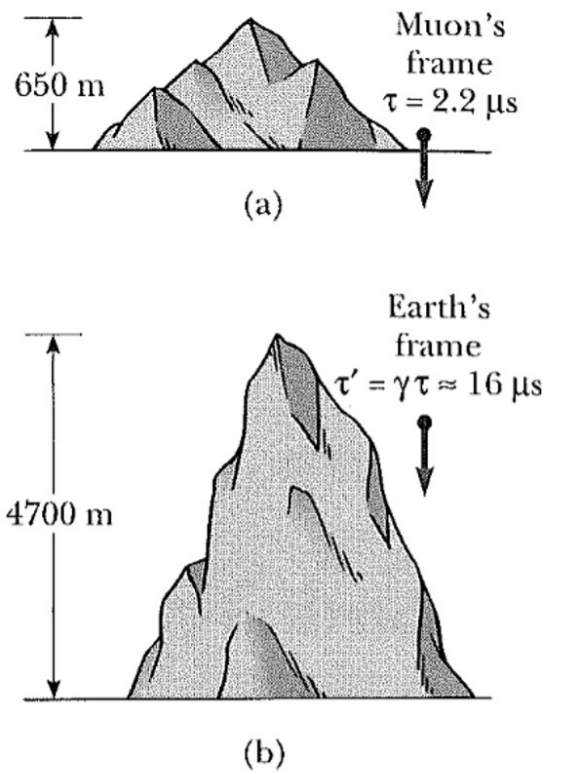

Length Contraction

"A moving length will appear shorter (in the direction of v)" – for a stationary observer.

At what speed does relativistic effects become significant?

$$t_0 = 1.00 \text{ s}$$
$$t > 1.005 \text{ s}$$
$$\frac{v}{c} = ?$$

$$T = \frac{T_0}{\sqrt{1 - v^2/c^2}}$$

$$\frac{T}{T_0} = \frac{1}{\sqrt{1 - v^2/c^2}}$$

$$\left(\frac{T_0}{T}\right)^2 = 1 - v^2/c^2$$

$$v^2/c^2 = 1 - \left(\frac{T_0}{T}\right)^2$$

$$v/c = \sqrt{1 - \left(\frac{T_0}{T}\right)^2}$$
$$= \sqrt{1 - \left(\frac{1}{1.005}\right)^2}$$

$$= 0.0996$$

$$v = 0.0996c \quad \approx 10\%$$

WACE 2019

Question 9

(3 marks)

With the use of a relevant formula, explain why time dilation is negligible at a speed of 100 km h^{-1} .

Relativistic Kinetic Energy

Experimentally, one finds that the energy required to accelerate an object of mass m to speed v is NOT:

$$E_k \neq \frac{1}{2} m v^2 \quad \text{Unless } v \ll c$$

Instead, we find that the required energy grows rapidly as v approaches c . The equation becomes:

DATA SHEET

$$p = \frac{m v}{\sqrt{\left(1 - \frac{v^2}{c^2}\right)}}$$

DATA SHEET

Rest energy $E = m c^2$

Mass-energy equivalence $E = \frac{m c^2}{\sqrt{1 - \frac{v^2}{c^2}}}$

NOT IN SYLLABUS

$$E_k = \frac{m_0 c^2}{\sqrt{1 - \frac{v^2}{c^2}}} - m_0 c^2 = m_0 c^2 (\gamma - 1)$$

Question 1

(3 marks)

Consider the voltage between two metal plates of $V = 5.00$ MV. An electron is released from rest near the negative plate. If a classical mechanics model is used, then:

$$W = \Delta E = E_f - E_i = \frac{1}{2} m v^2 - \frac{1}{2} m u^2 = qV$$

$$\frac{1}{2} m v^2 = qV$$

$$v = \sqrt{\frac{2qV}{m}} = 5.90 \times 10^8 \text{ m s}^{-1}$$

This is clearly not the correct velocity. Relativistic effects must be considered.

$$E_k = \frac{m_0 c^2}{\sqrt{1 - \frac{v^2}{c^2}}} - m_0 c^2 = m_0 c^2 (\gamma - 1)$$

Question 2

(5 marks)

Currently, the Large Hadron Collider at CERN is accelerating protons up to energies in the order of 13.0 TeV. The relativistic speeds these protons again are:

YOU TRY

Relativistic Relative Velocities

We know the speed limit (Postulate 2) is the speed of light, no object can be seen to be travelling faster than this value. Classical relativity suggests that if a spaceship receding from an observer at $0.6c$ was to fire a missile from itself at $0.7c$, the observer would see the missile receding at:

$$\begin{aligned} u &= v + u' \\ &= 0.6c + 0.7c \\ &= \mathbf{1.3c} \end{aligned}$$

This, of course, breaks all of the rules.

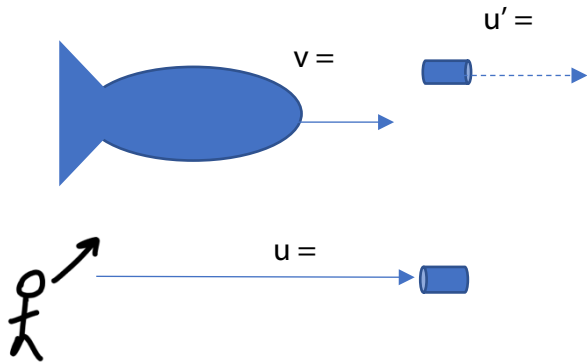

DATA SHEET

$$u = \frac{v + u'}{1 + \frac{vu'}{c^2}}$$

The observed recession of the missile is then:

$$\begin{aligned} u &= \frac{0.6c + 0.7c}{1 + \frac{0.6c \times 0.7c}{c^2}} \\ &= \frac{1.3c}{1 + \frac{0.42c^2}{c^2}} = \frac{1.3c}{1.42} = 0.92c \end{aligned}$$

The equation works with relative velocities in either direction. A sign convention must apply relative to a frame of reference. Consider the same space ship that now fires the missile backwards at a speed of $0.3c$

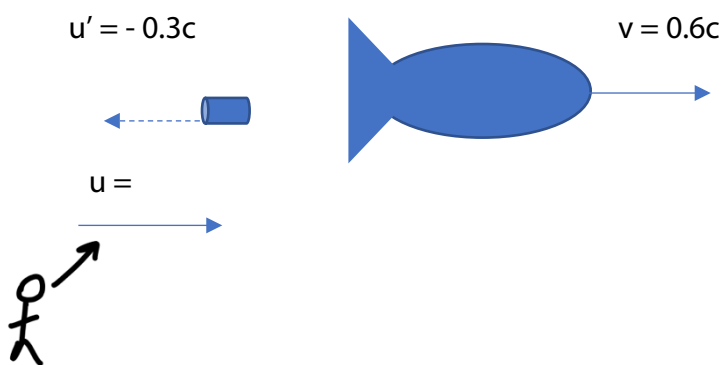

The observed recession of the missile is then:

$$\begin{aligned} u &= \frac{0.6c - 0.3c}{1 + \frac{0.6c \times -0.3c}{c^2}} \\ &= \frac{0.3c}{1 + \frac{-0.18c^2}{c^2}} = \frac{0.3c}{0.82} = 0.365c \end{aligned}$$

Or we could use the other equation in the data sheet:

DATA SHEET

Consider two spacecrafts both travelling at $0.8c$ as measured by a stationary observer and moving apart from each other. In this case, u and v are always from the same observer.

$$u' = \frac{u - v}{1 - \frac{v u}{c^2}}$$

u' is always measured from the frame of reference that was given v by the stationary observer.

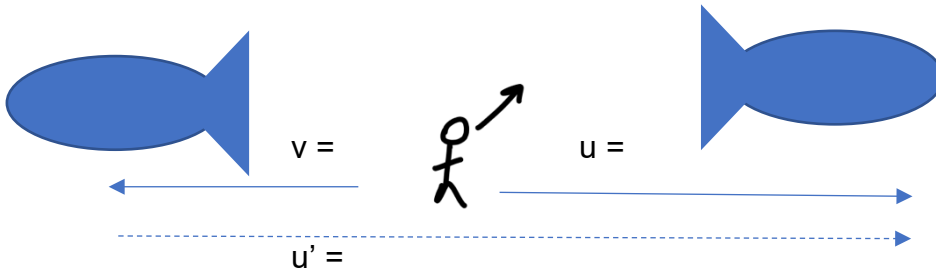

We could take a Galilean transform and look at these objects motion from the perspective of one of the pilots in the spacecraft. In this case, the “stationary observer is now moving away at $0.8c$ (v) and we have u' which is the measurement of the left spacecraft (as measured from that which was given v). So u will now be the speed of left space craft as measured from the pilot in the right spacecraft.

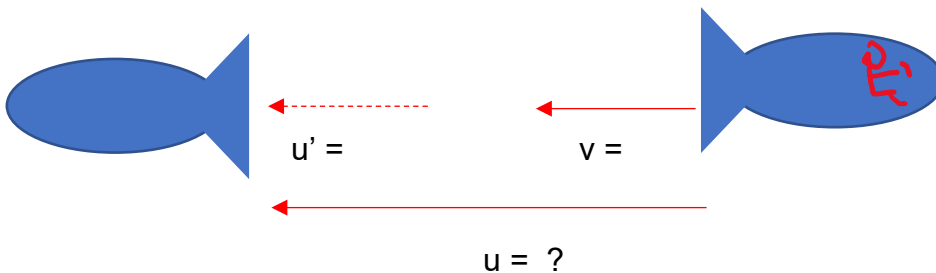

In summary:

- u' is always measured from the frame of reference that was given v by the stationary observer.
- u and v are always measured from the “observers reference frame”
- draw a diagram to determine u , v and u'
- use a sign convention for opposing velocities

Question 3**(4 marks)**

You are standing on Earth observing a dogfight between two fighter jets. One of them, flying at 1200 m s^{-1} , fires a missile at 700 m s^{-1} when directly overhead of your position.

Calculate the relative velocity of the missile as observed by you using:

(a) Classical physics principles.

(1 mark)

(b) Relativity theory.

(3 marks)

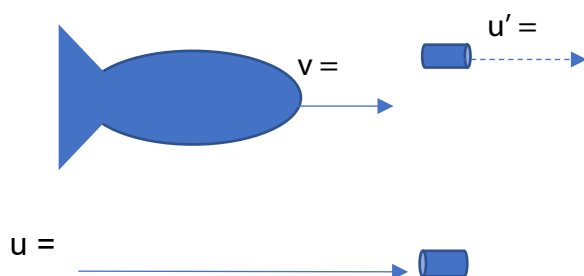
**Question 4****(3 marks)**

A radioactive nucleus travelling away from you at $0.25c$ in your frame of reference undergoes decay and emits a beta particle in its direction of travel at $0.65c$ relative to the remaining nucleus. What is the velocity of the beta particle relative to you?

YOU TRY

Question 5**(6 marks)**

A spaceship in distress sends out two escape pods named “Alpha” and “Delta” in opposite directions. Relative to the spaceship, Alpha travels at speed $v_A = -0.15c$ and Delta travels at speed of $v_D = +0.16c$

- (a) Calculate the relative velocity of escape pod Alpha as observed from escape pod Delta’s frame of reference.

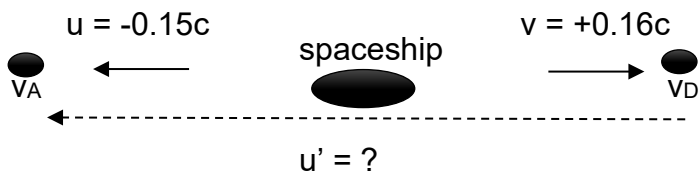
(3 marks)

- (b) Reverse your sign conventions from part (a) to show that the magnitude of the relative velocity remains the same.

(3 marks)**YOU TRY**

Question 19

- (h) If the rest mass energy of a proton is 938 MeV, calculate the velocity the proton reaches when accelerated to a kinetic energy of 1.4 GeV. (4 marks)

Answer _____ c

Name:

/ 12

Quiz: Relativity

1. A radioactive particle has a mean half-life of 5.35×10^{-4} s. Calculate the half-life of the particle as it travels past a stationary observer at a speed of 2.30×10^8 m s⁻¹. (4 marks)

2. A spacecraft races past an observer at $0.666c$ and is observed to be 49.7 m in length. Calculate the length of the spacecraft as measured by its occupants. (3 marks)

3. The Kaon particle has a rest mass of 8.80×10^{-28} kg. Calculate the speed the Kaon must be travelling to have a relativistic mass of 5.00x its rest mass.

(5 marks)

$$m = \frac{m_0}{\sqrt{1 - \frac{v^2}{c^2}}}$$

References

The Michelson Morley Experiment, BigHead, 2004, accessed 20th September 2020,
<<https://commons.wikimedia.org/wiki/File:Michelson-morley.png>>

Lorentz Factor Graph, Klamann, 2009, accessed 20th September 2020,
<<https://commons.wikimedia.org/wiki/File:Lorentzfaktor.svg>>